

# Beyond Raptor Platform

## Introduction

Beyond Raptor Platform includes FPGA/ASIC SoC design based on a 32-bit Processor Core (Beyond BA12 or BA22 Processor) that allows customers to take it as a base design and modify it into their own FPGA/ASIC SoC. Beyond Raptor Platform is delivered as a set of preinitialized FPGA development board, software development tools for the Beyond BA12 or BA22 Processor, Linux source code, and documentation.

## Features

Beyond Raptor FPGA/ASIC SoC consists of several modular units.

### 32-bit Processor Core

- **Beyond BA12 Processor**
  - ARM9™ class of processors
  - 1.02 DMIPS/MHz
  - low cost entry level processor, fully OpenRISC compatible
- **Beyond BA22 Processor**
  - ARM9™/ARM11™ class of processors
  - 1.36 DMIPS/MHz
  - world-leading code density (better than ARM Thumb2®)
  - low power design
  - 10%-40% better performance than Beyond BA12 Processor
- Complete software development toolchain
- Linux operating systems
- Power management unit
- Advanced debug unit allowing in-circuit debugging, hardware breakpoints, complex breakpoint and watchpoint conditions
- Integrated tick timer
- Programmable interrupt controller
- Optional custom instructions

Customer can select which of the following

processors will be preinitialized.

### Beyond MAC 10/100/1000 Controller

- IEEE 802.3-2002 specification with preamble, start-of-frame delimiter (SFD), frame padding generation and cyclic redundancy code (CRC) generation and checking is fully implemented
- MDIO Master interface for PHY device configuration and management
- Linux driver provided

### Beyond UART16550 Serial Controller

- Compatible with PC16550D/16450
- FIFO depth of 16 bytes in 16550 mode
- Linux driver provided

### Beyond DDR SDRAM Memory Controller

- Configured to support DDR2 devices
- Memory IF running at 2x WISHBONE IF speed
- Single WISHBONE port implemented

### Beyond FLASH/SSRAM Memory Interface

- Supports most asynchronous FLASH devices connected to first chip select
- Supports most asynchronous SRAM devices connected to second chip

- select
- Runtime configurable address decoder
- Bootstrap pin for initial address decoding setup
- Compile time configurable memory timings/latencies

- WISHBONE SoC Interconnection Rev B compliant interface

## Easy and Quick Start

### **Beyond AC97 Audio Controller**

- Built-in DMA controller
- AC97 component specification rev2.3 compliant
- Hardware variable sample rate support from 8kHz to 48kHz (up to 96kHz with Double Rate Audio enabled)

### **Beyond TAP Controller**

- JTAG Test Access Port (TAP) controller
- Fully compliant with IEEE 1149.1-2001 standard

### **Beyond Debug Controller**

- Access to internal CPU registers, WISHBONE and QMEM buses over TAP interface

### **Beyond VGA Display Controller**

- CRT and LCD display support with user programmable resolutions and video timings
- Bus master for independent operation from the processor

### **Beyond GPIO Controller**

- 16 GPIOs (max 32)

### **Beyond PS/2 Controller**

- PS/2 communication with either keyboard or mouse device

### **Deliverables**

- Software development tools for Linux and Cygwin on Windows
- Operating system and Board Support Package for Beyond Raptor FPGA/ASIC SoC
- Development board preinitialized with Beyond RaptorPlatform including Linux kernel
- Engineering support

### **Software Development Tools**

- ANSI C, C++ compiler (GCC)
- Debugger, linker, assembler and utilities
- Architectural simulator
- Supported platforms Linux and Cygwin on Windows

Third party software development tools will be available in the future.

### **Operating Systems**

- Linux 2.6.x kernel port for Beyond BA1 and BA2 Architecture

### **Target Applications**

- Internet, networking and telecom
- Embedded
- Portable and wireless
- Home entertainment consumer electronics
- Automotive

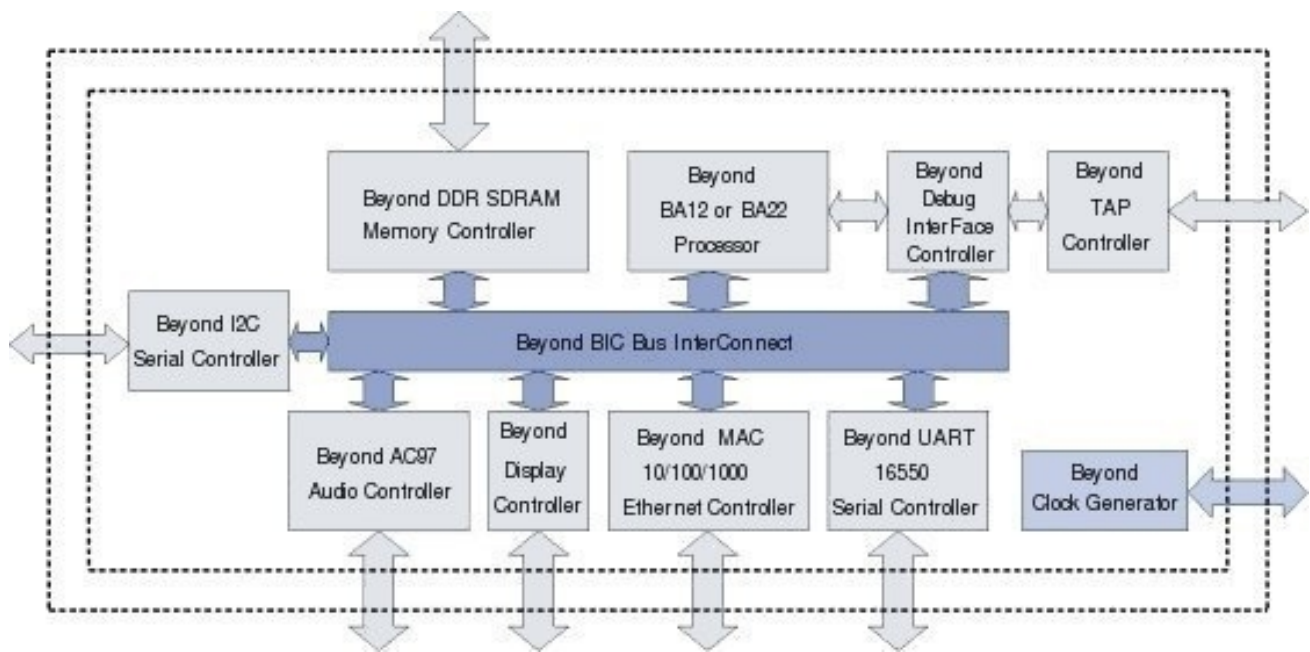

Beyond Semiconductor reserves the right to make changes in specifications at any time and without notice. The information furnished by Beyond Semiconductor in this publication is believed to be accurate and reliable. No responsibility, however, is assumed by Beyond Semiconductor for its use, nor for any infringements of patents or other rights of third parties resulting from its use. No license is granted under any patents or patent rights of Beyond Semiconductor. This product is intended for use in normal commercial applications. Use of this product in applications such as life-support or life-sustaining equipment is specifically not authorized without the express written approval of the president of Beyond Semiconductor.